

Assembly No. and Serial No. Information

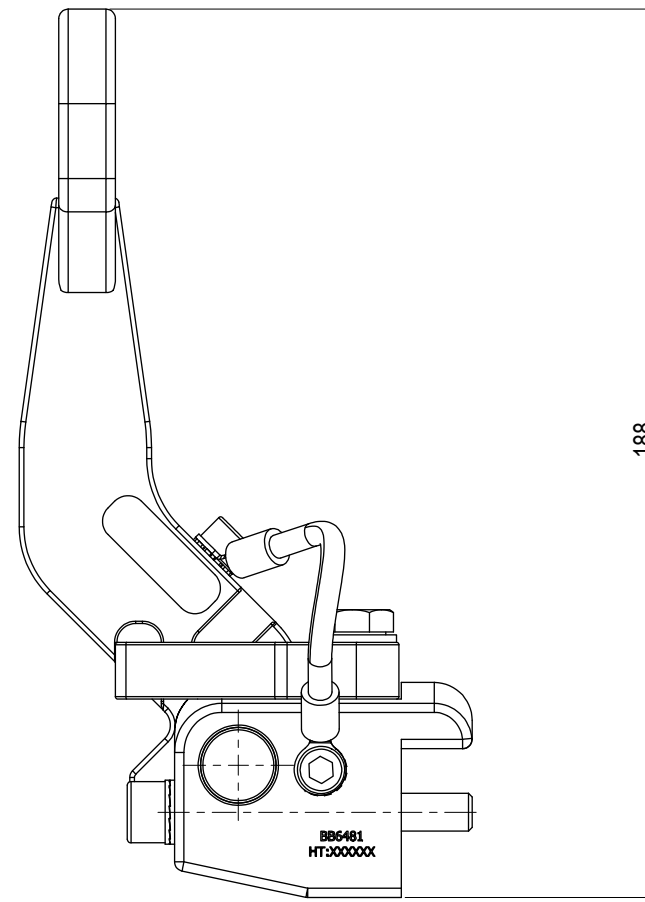
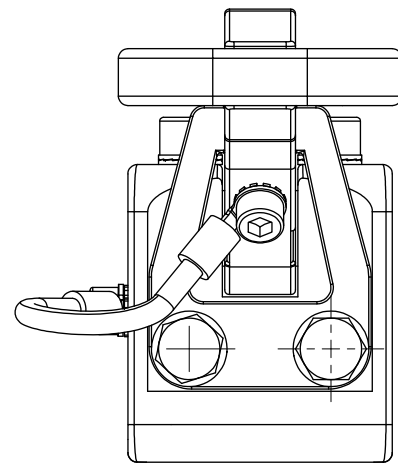
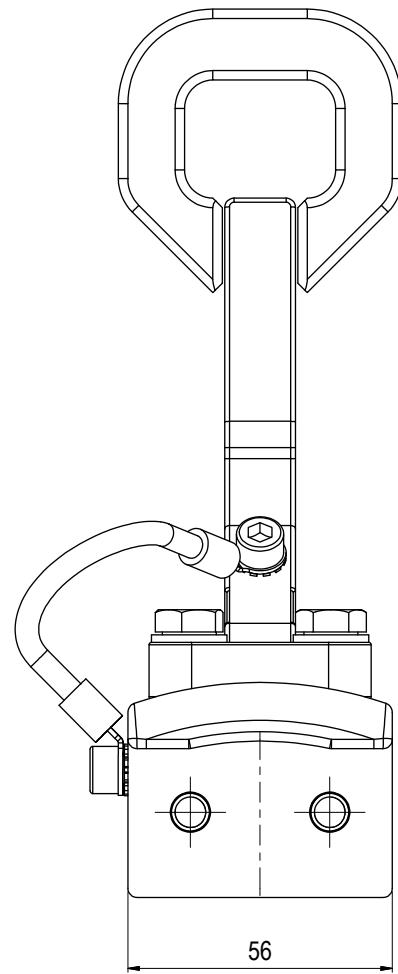

188

NOTE: 1  
DESIGN CODE:  
N/A

NOTE: 2  
TECHNICAL CLASSIFICATION:  
Article Type: 003-Valve Stabs  
Main Group: 3.07. Ø55/Ø57-Valvestab  
Intermediate Group: 3.42.02. Receptacle  
Sub Group: 3.42.103.6. Hexa

NOTE: 3  
INTERFACE INFORMATION:  
Pressure Rating Bar: N/A  
Material: N/A  
Weight: 1,4 kg  
Volume: 0,2 dm<sup>3</sup>  
Surface Area: 642 cm<sup>2</sup>  
Hydraulic: N/A  
Mechanical: N/A  
Electrical: N/A  
Com. & Protocol: N/A

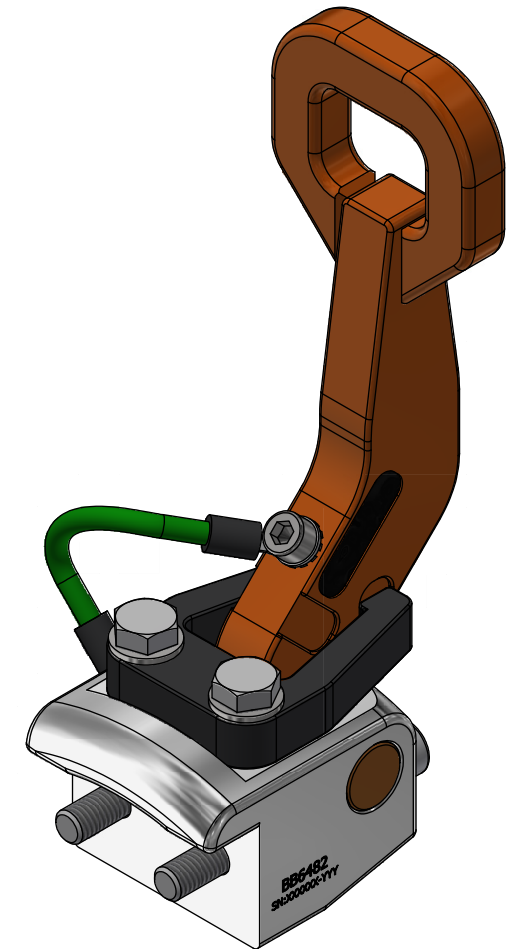

Rev.	Date	Reason for issue	Revision change	Made	Chk'd	Appr.
03	22.8.2023	9-IFU (Issued for Use)		HNJ	LGH	HNJ
02	29.4.2021	7-IFC (Issued for Construction)		WTJ	HNJ	WTJ
01	16.4.2021	7-IFC (Issued for Construction)		HNJ	LGH	HNJ



Dwg Scale:	NTS
Dwg Proj:	
Dwg Format:	A3

Drawing title:	Lock Mechanism Ø55/Ø57 HP VStab V2 Universal	
Drawing number:	BB6482	Rev: 03